

megamount 509

**SMONTAGOMME PER VETTURE
E VEICOLI COMMERCIALI LEGGERI**

**TYRE CHANGER FOR CARS
AND LIGHT COMMERCIAL VEHICLES**



MADE IN



CE



megamount 509

SMONTAGOMME CON BRACCIO RIBALTABILE ALL'INDIETRO PER VETTURE E VEICOLI COMMERCIALI LEGGERI

TYRE CHANGER FOR CARS AND LIGHT COMMERCIAL VEHICLES WITH BACK TILTING ARM



Smontagomme automatico con braccio ribaltabile all'indietro. Bloccaggio cerchio da 10" a 24".

- Adatti per vetture, veicoli commerciali leggeri e moto (con adattatori opzionali)
- Basamento di dimensioni maggiorate per poter operare in sicurezza anche su ruote di grandi dimensioni
- Pedaliera estraibile per una manutenzione facilitata
- Lubrificatore
- Alimentazione standard trifase a 230 o 400 Volt, 50 o 60 Hz (opzionale monofase)
- Sistema di gonfiaggio a pedale completo di manometro
- Doppia velocità di rotazione a pedale
- Braccio in aiuto UHP2



Desmontadora automática con vuelco del brazo hacia atrás. Bloque llanta de 10" a 24".

- Adaptos para autos, vehículos comerciales y motos (con adaptadores opcionales)
- Basamento de dimensiones aumentadas para poder operar en seguridad también sobre ruedas de grandes dimensiones
- Pedales extraíbles para una mantención facilitada
- Lubricador
- Alimentación estandar trifásica de 230 o 400 Volt, 50 o 60 Hz (opcional monofásico)
- Aparato de inflado a pedal con manómetro
- Doble velocidad de rotación, mando a pedal
- Brazo de ayuda UHP2



Máquina automática com braço reclinável. Fixação de jante da 10" a 24".

- Máquinas concebidas para pneus de ligeiros, comerciais e motociclos (com adaptadores opcionais)
- Resguardo de protecção de grandes dimensões, permitindo também trabalhar rodas mais pesadas com maior segurança
- Conjunto de pedais amovível para fácil manutenção
- Lubrificador
- Corrente standard Trifásica, 230 ou 400 Volt, 50 ou 60 Hz (opcional: Monofásica)
- Dispositivo de enchimento, comando de pedal e manómetro
- Duas velocidades de rotação, comando de pedal
- Dispositivo de ajuda UHP2



Automatic tyre changer with back tilting arm. Rim clamping from 10" to 24".

- Suitable for cars, light commercial vehicles and motorcycles (with optional clamps)
- Bigger size casing to operate in safety conditions with big size wheels as well
- Extractable pedal drawer for an easy servicing
- Lubricator
- Standard three-phase power supply, 230 or 400 Volt, 50 or 60 Hz (optional: single phase)
- Pedal controlled inflating system complete with pressure gauge
- Double speed pedal control
- UHP2 help arm



Démonte pneus automatique avec bras basculant en arrière. Blocage jante de 10" à 24"

- Indiqués pour voitures, véhicules commerciaux légers et motocyclettes (avec mâchoires en option)
- Bâti renforcé pour travailler en sécurité même sur roues de grandes dimensions
- Pédalier extractible pour un entretien aisé
- Lubricateur
- Alimentation standard triphasée à 230 ou 400 Volt, 50 ou 60 Hz (monophasée en option)
- Dispositif de gonflage à pédale complète avec manomètre
- Double vitesse à pédale
- Dispositif Press Arm UHP2



Automatisches Reifenmontiergerät mit nach hinten kippbarem Montagearm. Felgeneinspannung von 10" bis 24".

- Geeignet für PKW, Kleintransporter und Motorräder (mit optional erhältlichen Adaptern)
- Rahmen mit erhöhten Abmessungen für mehr Arbeitssicherheit bei grossen Rädern
- Ausziehbare Fusssteuervorrichtung zur erleichterten Wartung
- Schmiervorrichtung
- Standard-Stromzufuhr dreiphasig: 230 oder 400 Volt, 50 oder 60 Hz (einphasig als Option)
- Pedalbetätigte Füllvorrichtung komplett mit Manometer
- Doppelte Drehgeschwindigkeit (durch Pedal)
- UHP2 Press-Arm

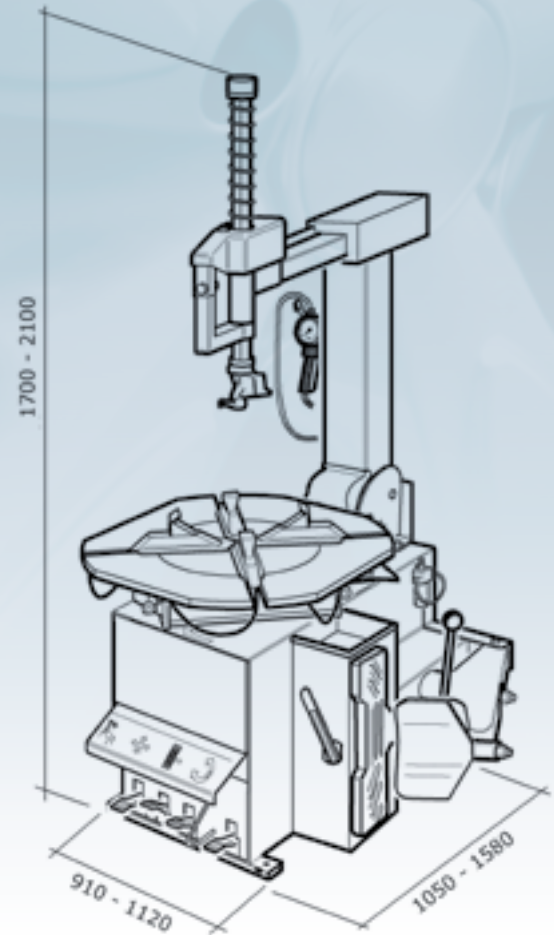

DATI TECNICI

DATOS TÉCNICOS

DADOS TÉCNICOS

MEGAMOUNT 509

Bloccaggio cerchio esterno	Bloque llanta desde el exterior	Fixação da jante Exterior	10" - 22"
Bloccaggio cerchio interno	Bloque llanta desde el interior	Fixação da jante Interior	12" - 24"
Diametro max. ruota	Diámetro máx. rueda	Max. Diámetro da Roda	1000 mm (39")
Larghezza max. ruota	Ancho máx. rueda	Max. Largura da Roda	356 mm (14")
Forza cilindro stallonatore a 10 bar	Fuerza cilindro destalonador a 10 bar	Força do cilindro descolador a 10 bar	30800 N
Pressione d'esercizio	Presión de trabajo	Pressão de funcionamento	10 bar (145 psi)
Alimentazione	Alimentación	Energia	230/400 V 3ph
Potenza motore	Potencia motor	Potência do motor	0,55 kW
Coppia max. mandrino	Par máx. del mandril	Binário Max. de rotação	1150 Nm
Limitatore pressione gonfiaggio max.	Dispositivo limitador de presión de inflado máx.	Limitador de pressão de insuflação max.	3,5 bar (50 psi)
Livello di rumorosità in condizioni di lavoro	Nivel de rumor en condición de trabajo	Nível de ruído em condições de funcionamento	<70 dBA
Peso Netto	Peso neto	Peso neto	Kg 305
Dimensioni imballo	Dimensiones embalaje	Dimensões de embalagem	1065x760x1065 h (mm)

STANDARD FEATURES

DONNÉES TECHNIQUES

TECHNISCHE DATEN

MEGAMOUNT 509

Rim clamping from outside	Blocage jante de l'extérieur	Felgeneinspannung von außen	10" - 22"
Rim clamping from inside	Blocage jante de l'intérieur	Felgeneinspannung von innen	12" - 24"
Max. wheel diameter	Diamètre maxi. roue	Max. Raddurchmesser	1000 mm (39")
Max. wheel width	Largeur maxi. roue	Max. Radbreite	356 mm (14")
Bead-loosener cylinder force at 10 bar	Force cylindre détalonneur à 10 bar	Kraft des Wulstabdruckzylinders bei 10 bar	30800 N
Operating pressure	Pression de service	Betriebsdruck	10 bar (145 psi)
Power supply	Alimentation	Stromzufuhr	230/400 V 3ph
Motor power	Puissance moteur	Motorleistung	0,55 kW
Max. spindle torque	Couple maxi. mandrin	Max. Kräftepaar an der Hauptspindel	1150 Nm
Inflating pressure limiting device max.	Dispositif limiteur de pression de gonflage maxi.	Vorrichtung zur Reifenfülldruckbegrenzung max.	3,5 bar (50 psi)
Noise level	Niveau de bruit	Geräuschpegel	<70 dBA
Net weight	Poids net	Nettogewicht	Kg 305
Packing dimensions	Dimensions emballage	Verpackungsabmessungen	1065x760x1065 h (mm)

**ACCESSORI OPZIONALI - ACCESORIOS OPCIONALES - ACESSÓRIOS OPCIONAIS
OPTIONAL ACCESSORIES - EQUIPEMENT EN OPTION - SONDERZUBEHÖR**

 Alimentazione **MONOFASE** 110 o 230 Volt, 50 o 60 Hz.
Adattatori ruote moto e filtro regolatore di pressione con manometro.
Dispositivo pneumatico **PRESS-ARM** per operare su pneumatici a profilo ribassato.

 Alimentación **MONOFASICA** 110 o 230 Volt, 50 o 60 Hz.
Adaptadores ruedas de moto y filtro regulador de presión con manómetro.
Dispositivo neumático **PRESS-ARM** para operar sobre neumáticos de perfil rebajado.

 Corrente **MONOFÁSICA**, 110 ou 230 Volts, 50 ou 60 Hz
Adaptadores para roda de motociclos e filtro regulador de pressão com manómetro.
Dispositivo **"PRESS-ARM"** para trabalhar com pneus de baixo perfil.

 **SINGLE-PHASE** power supply, 110 or 230 Volt, 50 or 60 Hz.
Clamps for motorcycle wheels and pressure gauge with manometer.
PRESS-ARM device to operate on low-profile tyres.

 Alimentation **MONOPHASEE** 110 ou 230 Volt, 50 ou 60 HZ.
Mâchoires roues moto et réducteur de pression avec manomètre.
Dispositif pneumatique **PRESS-ARM** pour travailler sur pneus surbaissés.

 Stromzufuhr **einphasig** mit 110 oder 230 Volt, 50 oder 60 Hz.
Adapter für Motorräder und Druckregler mit Manometer.
Pneumatisch betätigte Vorrichtung **"PRESS-ARM"** zur Bearbeitung von Niederquerschnittsreifen.

**DOTAZIONE STANDARD - DOTACIÓN ESTANDAR - ACESSÓRIOS STANDARD
STANDARD ACCESSORIES - EQUIPEMENT STANDARD - STANDARDZUBEHÖR**

 Leva alzataloni
Lubrificatore
Pennello
Protezioni in plastica

 Leva entalonadora
Lubrificador
Pincel
Protecciones en plastico

 Alavanca de descolamento do talão do pneu
Lubrificador
Pincel
Proteção em plástico

 Lever for bead lifting
Lubricator
Tin for fat with holder and brush
Plastic covers

 Levier soulève talons
Lubrificateur
Boîte pour graisse et pinceau
Protections en plastique

 Wulstabdrückhebel
Schmiervorrichtung
Behälter für Schmiere
Pinsel
Plastikschutze



UHP2:
Dispositivo di aiuto
Dispositivo de ayuda
Dispositivo de ajuda
Help device
Dispositif help
Help-Vorrichtung



HOFMANN MEGAPLAN GmbH
Hauptstraße 67
A-5302 Henndorf · Austria
Tel +43-6214-646612 · Fax 646622
hm-mail@hofmann-megaplan.com
www.hofmann-megaplan.com

Distribuidor

REDIMAUTO
Venta y Reparación de Maquinaria para Automoción

AGH505140