



## FALCO AL 530 ITR

### EN

The Falco AL 530 ITR was designed for changing large tyres. The self-centering device is low for easy loading and, together with the double height pole, permits use of wheels up to 14" in width; the adjustable mobile tracks, instead, can be used for rims up to 30". A convenient pedal controls the two speed motor and ensures greater operating versatility. The inflating device for tubeless tyres, in the tracks, makes it possible to inflate even the most awkward of tyres.

### IT

Falco AL 530 ITR è uno smontagomme studiato per lavorare su ruote di grandi dimensioni. La posizione ribassata dell'autocentrante facilita le operazioni di Carico, ed unito al palo a doppia altezza consente di operare su ruote di larghezza massima fino a 14"; le corsie registrabili invece possono bloccare cerchi fino a 30". Un comodo pedale controlla le due velocità di rotazione e permette di sfruttare al meglio la potenza del motore. Il sistema gonfiatubeless integrato nelle corsie consente di intallare anche i pneumatici più difficili.

### ES

Falco AL 530 ITR es un desmontador de neumáticos estudiado para trabajar sobre ruedas de grandes dimensiones. La posición baja del centrado automático facilita las operaciones de carga, y unido al palo de doble altura permite operar en ruedas de ancho máximo de hasta 14". Los carriles registrables en cambio, pueden bloquear círculos de 30". Un cómodo pedal controla las dos velocidades de rotación y permite aprovechar al máximo la potencia del motor. El sistema para inflado de neumáticos Run Flat de los carriles permite inflar también los neumáticos más difíciles.



**EN**

The sliding arm is connected at two points and guarantees optimal locking.

**IT**

Il braccio scorrevole agganciato in due punti garantisce un bloccaggio ottimale.

**ES**

El brazo corredizo enganchado en dos puntos garantiza un bloqueo óptimo.

**EN**

Racing Pole:

- Allows operation on wheels of up to 14" width
- Dual height selection; minimises flexion.

**IT**

Palo Racing:

- permette di operare su ruote fino a 14" di larghezza
- doppia altezza selezionabile per ridurre al minimo le flessioni.

**ES**

Columna Racing:

- permite trabajar ruedas de hasta 14" de ancho
- doble altura seleccionable reduciendo al mínimo las flexiones

**EN**

The tubeless tyre inflating device is integrated into the locking tracks, with direct transfer via gearbox, allowing for a stronger air flow.

**IT**

Dispositivo gonfia tubeless integrato nelle corsie di bloccaggio, con passaggio diretto attraverso il motoriduttore, che permette una maggiore potenza del getto d'aria.

**ES**

Dispositivo de inflado tubeless incorporado en los carriles de bloqueo, con pasaje directo a través del motorreductor, que permite una mayor potencia del chorro de aire.

**EN**

Pedal switch controlled two-speed self-centering device (three-phase version only) and adjustable mobile tracks with the possibility of gripping on the outside till 30".

**IT**

Autocentrante a 2 velocità con comando a pedale (solo versione trifase) e corsie mobili registrabili con possibilità di presa esterna fino a 30".

**ES**

Centrado automático de 2 velocidades con mando de pedal (solo versión trifásica) y carriles móviles registrables con posibilidad de toma externa hasta 30".

**EN**

The three possible positions of the racing bead breaker and the tilting arm permit the changing of wheels up to 370 mm in width, optimizing air consumption and turnaround.

**IT**

Le tre diverse possibili registrazioni dello stallonatore racing permettono di lavorare su ruote fino a 370 mm di larghezza ottimizzando i consumi di aria e tempo.

**ES**

Los tres distintos registros posibles del destalonador de carrera y la paleta basculante permiten trabajar en ruedas de hasta 370 mm de ancho optimizando los consumos de aire y tiempo.



## Optional accessories / Optional / Extras



### EN

Tecnoroller with helper arm to simplify loading/unloading, of UHP-RFT tyres in particular (available on request).

### IT

Tecnoroller completo di braccio helper che semplifica il montaggio/smontaggio, in particolare di pneumatici UHP-RFT (optional).

### ES

Tecnoroller con brazo de ayuda que simplifica el montaje/desmontaje, es especial de neumáticos UHP-RFT (opcional).

PN:404012200001



- Tecnoroller XL
- Tecnoroller XL
- Tecnoroller XL

PN: 104880-GB



- Lifting device "SIDELIFT"
- Sollevatore "SIDELIFT"
- Elevador "SIDELIFT"

PN: 1 695 104 071



- Track protection
- Kit protezioni corsia
- Kit protecciones carril

PN: 1 695 106 152



- Nylon protection for bead breaker blade
- Protezione in nylon per paletta stallonatore
- Protección de nylon para paleta destalonadora

PN: 1 695 105 191



- Rim protection
- Protezione cerchio
- Protección llanta

PN: 1 695 103 210

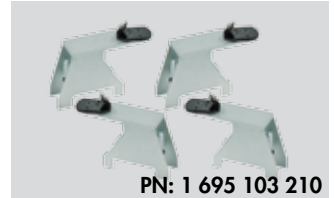

- Scooter attachments kit
- kit attacchi scooter
- kit conexiones scooter

PN: 1 695 103 302



- Bead locking clamp
- Pinza bloccaggio tallone
- Pinza bloqueo talón

PN: 1 695 103 252



- Motorbike bead breaker support unit
- Gruppo appoggio stallonatore moto
- Grupo apoyo destalonador moto

PN: 1 695 103 547



- Motorbike attachments kit
- Kit attacchi moto
- Kit adaptadores moto

PN: 1 695 106 190

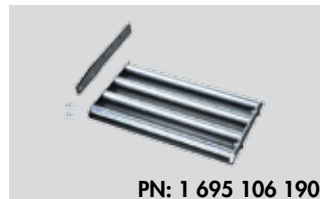

- Roller board
- Rulliera
- Transportador de rodillos

PN: 1 695 102 725



- Turret wing protection
- Protezione ala torretta
- Protección ala torreta

PN: 1 695 103 210



- Plastic motorbike turret + adapter
- Torretta moto in plastica + adattatore
- Torreta moto de plástico + adaptador

PN: 1 695 103 261 - 1 695 103 216



- Low wedge and high wedge
- Zeppa bassa e zeppa alta
- Cuña baja y cuña alta

PN: 103551-GB



- Storage unit
- Gruppo storage
- Grupo storage

PN: 1 695 101 608



- Turret tab protection kit (5 pce)
- Kit (5 pz) protezione linguetta torretta
- kit (5 pzs) protección lengüeta torreta

## Dimension / Ingombro / Dimension

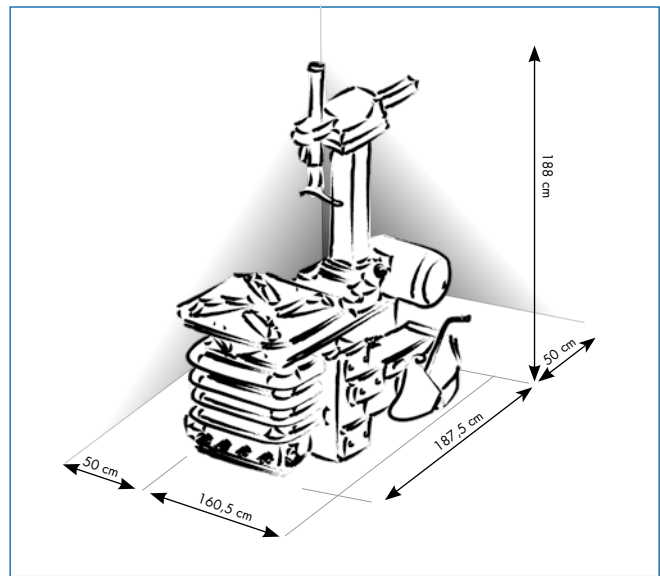

www.glabcorreggio.it

## Specification / Dati tecnici / Datos Técnicos

AL 530 ITR	270	110V 1ph 230V 1 ph 230/400V 3 ph	1hp 1hp 1,2-1,7 hp	7 rpm 7 rpm 7-15 rpm	8 - 12 bar	12"-30"	14"-32"	14"	1200	10000N

# SICAM

**Sicam S.r.l. Società Unipersonale A Bosch Group Company**  
 Via G. Corradini- 42015 Correggio (R.E) Italy  
 Tel. +39 0522 643.311 – Telefax +39 0522 637.760  
 E-mail: sales@sicam.it – <http://www.sicam.it>

Contact dealer / Spazio Riservato al Rivenditore / Espacio para el distribuidor

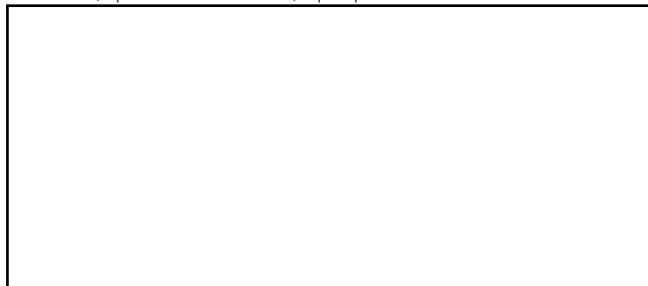

Cod. 1.695 D10 040 / 2011-06-16