

PN: 104880-GB



- Lifting device "SIDELIFT"
- Sollevatore "SIDELIFT"
- Elevador "SIDELIFT"



PN: 1 695 106 152

- Nylon protection for bead breaker blade
- Protezione in nylon per palette stallonatore
- Protección de nylon para paleta destalonadora



PN: 1 695 103 302

- Bead locking clamp
- Pinza bloccaggio tallone
- Pinza bloqueo talón

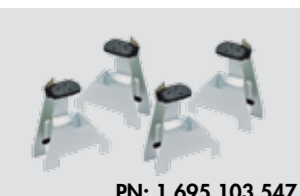

PN: 1 695 103 547

- Motorbike attachments kit
- Kit attacchi moto
- Kit adaptadores moto



PN: 1 695 906 476

- Storage unit
- Gruppo storage
- Grupo storage



PN: 1 695 105 191

- Rim protection
- Protezione cerchio
- Protección llanta



PN: 1 695 103 211

- Plastic turret + adapter kit
- Kit torretta in plastica + adattatore
- Kit torreta de plástico + adaptador



PN: 1 695 104 071

- Track protection
- Protezione corsia
- Protección carril



PN: 1 695 103 210

- Plastic motorbike turret + adapter
- Torretta moto in plastica + adattatore
- Torreta moto de plástico + adaptador

### Dimension / Ingombro / Dimension

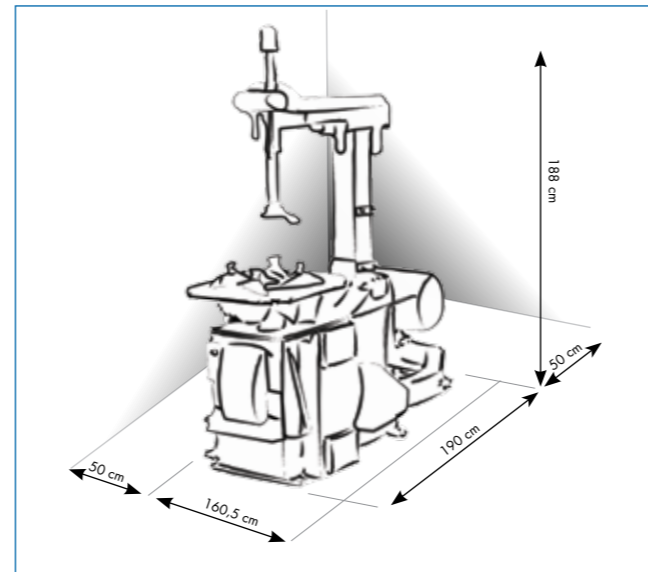

www.glabcorreggio.it

### EN

Automatic tyre changer ideal for use on cars and light vehicles wheels up to 26". The Falco NA 526 is suitable for operating on steel or aluminium rims or new generation tyres (UHP-RFT).

### IT

Smontagomme automatico ideale per operare su ruote vettura e trasporto leggero fino a 26". Falco NA 526 è l'attrezzatura adatta ad operare su cerchi in ferro o alluminio e pneumatici di nuova generazione (UHP-RFT).

### ES

Desmontadora de neumáticos automática ideal para trabajar ruedas de automóviles y de transporte ligero de hasta 26". Falco NA 526 es la herramienta indicada para trabajar llantas de hierro o de aluminio y neumáticos de nueva generación (UHP-RFT).



NA 524 XXXXX	110V 1ph 60Hz 230V 1ph 50-60Hz 400V 3ph 50Hz	1 hp 0,5 hp 1,50 hp	7 rpm 7 rpm 7 rpm
NA 526 XXXXX	230/400V 3ph 50-60Hz	1-1,5 hp	7-15 rpm

### Specification / Dati tecnici / Datos Técnicos

NA 524 ASR - NA 526 ASR	226 Kg.	8-10 bar	12"-29"	10"-26"	11"	1000 mm	10000 N	
NA 524 ITASR - NA 526 ITASR	240 Kg.	8-10 bar	12"-29"	10"-26"	11"/13"	1000 mm	10000 N	
NA 524 R - NA 526 R	288,5 - 225 Kg.	8-10 bar	12"-29"	10"-26"	13"	1000 mm	10000 N	
NA 524 ITR - NA 526 ITR	234,5 - 232 Kg.	8-10 bar	12"-29"	10"-26"	13"	1000 mm	10000 N	

Contact dealer / Spazio Riservato al Rivenditore / Espacio para el distribuidor





# Falco NA 526 ASR – Falco NA 526 ITASR

# Falco NA 526 R - Falco NA 526 ITR

## Optional accessories / Optional / Extras

**EN**  
Inflation system with fixed manometer on pole and pedal-operated control.

**IT**  
Sistema di gonfiaggio con manometro fisso sul palo e controllo a pedale.

**ES**  
Sistema de inflado con manómetro fijo en la columna y control de pedal.

**EN**  
The tubeless tyre inflating device is integrated into the locking tracks, with direct transfer via gearbox, allowing for a stronger air flow. (Only NA 526 ITASR)

**IT**  
Dispositivo gonfia tubeless integrato nelle corsie di bloccaggio, con passaggio diretto attraverso il motoriduttore, che permette una maggiore potenza del getto d'aria. (Solo NA 526 ITASR)

**ES**  
Dispositivo de inflado tubeless incorporado en los carriles de bloqueo, con pasaje directo a través del motorreductor, que permite una mayor potencia del chorro de aire. (Solo NA 526 ITASR)

**EN**  
Two speed self-centring device for greater versatility (three phase model only), single speed in NA 524 model.

**IT**  
Autocentrante a 2 velocità per una maggiore versatilità (solo versione trifase), a 1 velocità nella versione NA 524

**ES**  
Autocentrante de 2 velocidades para una mayor versatilidad (solo en la versión trifásica), de 1 velocidad en la versión NA 524

**EN**  
ASR pole:  
- Allows operation on wheels of up to 11" width and 1070 mm diameter.

**IT**  
Palo ASR:  
Permette di operare su ruote fino a 11" di larghezza e a 1070 mm di diametro.

**ES**  
Columna ASR:  
- Permite trabajar ruedas de hasta 11" de ancho y 1070 mm de diámetro.

**EN**  
The sliding arm is connected at two points and guarantees perfect locking.

**IT**  
Il braccio scorrevole agganciato in due punti garantisce un bloccaggio perfetto.

**ES**  
El brazo corredizo enganchado en dos puntos garantiza un bloqueo perfecto.



**EN**  
Tubeless tyre inflation device (only Falco NA 526 ITR)... see Falco NA 526 ITASR

**IT**  
Dispositivo gonfia tubeless (solo Falco NA 526 ITR)...vedi Falco NA 526 ITASR

**ES**  
Dispositivo de inflado tubeless (solo Falco NA 526 ITR)...vea Falco NA 526 ITASR

**EN**  
Racing Pole:  
- Allows operation on wheels of up to 13" width  
- Dual height selection; minimises flexion

**IT**  
Palo Racing:  
- permette di operare su ruote fino a 13" di larghezza  
- doppia altezza selezionabile per ridurre al minimo le flessioni.

**ES**  
Columna Racing:  
- permite trabajar ruedas de hasta 13" de ancho  
- doble altura seleccionable reduciendo al mínimo las flexiones



**EN**  
The three different adjustments of the Racing bead breaker allows operation on wheels of up to 390 mm width, optimising air and time consumption.

**IT**  
Le tre diverse possibili registrazioni dello stallonatore racing permettono di lavorare su ruote fino a 390 mm di larghezza ottimizzando i consumi di aria e tempo.

**ES**  
Los tres diferentes registros posibles del destalonador racing permiten trabajar ruedas de hasta 390 mm de ancho optimizando los consumos de aire y de tiempo.



- Tecnoroller SL
- Tecnoroller SL
- Tecnoroller SL



- Helper
- Helper
- Helper



- Button operated tubeless tyre inflation kit
- Kit Gonfiatubeless a pulsante
- Kit de inflado tubeless de pulsador



- Turret wing protection
- Protezione ala torretta
- Protección ala torreta



- Turret tab protection kit (5 pce)
- Kit (5 pz) protezione linguetta torretta
- kit (5 pzs) protección lengüeta torreta



- Low wedge and high wedge
- Zeppa bassa e zeppa alta
- Cuña baja y cuña alta



- Roller board
- Rulliera
- Transportador de rodillos



- Motorbike bead breaker support unit
- Gruppo appoggio stallonatore moto
- Grupo apoyo destalonador moto



- Scooter attachments kit (from 7")
- Kit attacchi scooter (da 7")
- Kit adaptadores scooter (de 7")

**EN** ASR pole  
3-position bead breaker  
pedal-controlled inflation

**IT** Palo ASR  
Stallonatore 3 posizioni  
Gonfiaggio a pedale

**ES** Columna ASR  
Destalonador 3 posiciones  
Inflado de pedal

**EN** RACING pole  
3-position bead breaker  
Pedal-controlled inflation

**IT** palo RACING  
Stallonatore 3 posizioni  
Gonfiaggio a pedale

**ES** Columna RACING  
Destalonador 3 posiciones  
Inflado de pedal