

FALCO NA 726

PN: 104880-GB



- Lifting device "SIDELIFT"
- Sollevatore "SIDELIFT"
- Elevador "SIDELIFT"



PN: 1 695 106 152

- Nylon protection for bead breaker blade
- Protezione in nylon per palette stallonatore
- Protección de nylon para paleta destalonadora



PN: 1 695 103 302

- Bead locking clamp
- Pinza bloccaggio tallone
- Pinza bloqueo talón



PN: 1 695 103 547

- Motorbike attachments kit
- Kit attacchi moto
- Kit adaptador moto



PN: 1 695 906 476

- Storage unit
- Gruppo storage
- Grupo storage



PN: 1 695 105 191

- Rim protection
- Protezione cerchio
- Protección llanta



PN: 1 695 103 211

- Plastic turret + adapter kit
- Kit torretta in plastica + adattatore
- Kit torreta de plástico + adaptador



PN: 1 695 104 071

- Track protection
- Kit protezioni corsia
- Kit protecciones carri



PN: 1 695 103 210

- Plastic motorbike turret + adapter
- Torretta moto in plastica + adattatore
- Torreta moto de plástico + adaptador

Dimension / Ingombro / Dimension

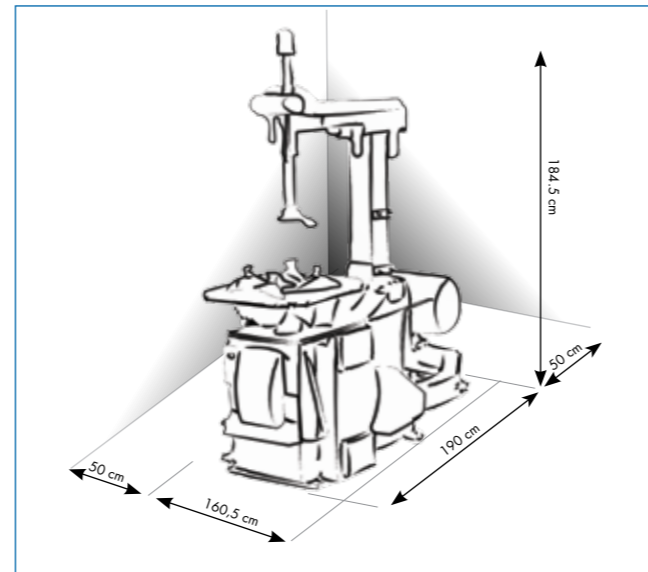

www.glabcorreggio.it

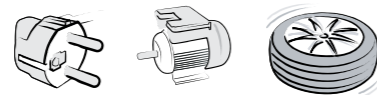

NA 724 XXXXX	110V 1ph 60 Hz 230V 1ph 50-60 Hz 230/400V 3ph 50 Hz	1 hp 0.5 hp 1,50 hp	7 rpm 7 rpm 7 rpm
NA 726 XXXXX	230-400V 3ph 50-60Hz	1-1,5 hp	7-15 rpm

Specification / Dati tecnici / Datos Técnicos

NA 724 R - NA 726 R	230 Kg.	8-10 bar	12"-29"	10"-26"	13"	1000 mm	10000 N	
NA 724 ITR - NA 726 ITR	245 Kg.	8-10 bar	12"-29"	10"-26"	13"	1000 mm	10000 N	

Contact dealer / Spazio Riservato al Rivenditore / Espacio para el distribuidor

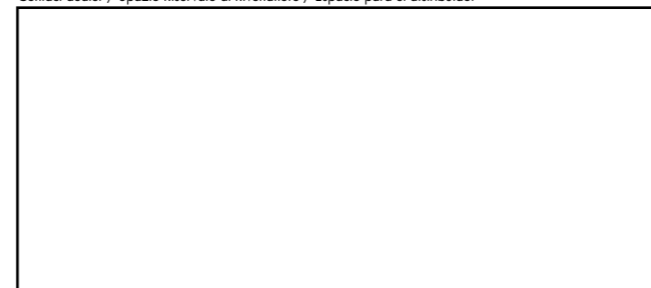

Cod. 1.695.D10.030-810 / 2011-12.06

EN

New completely automatic tyre changer ideal for use on cars and light vehicles wheels up to 26". Fitted with pneumatic positioning device, the Falco NA 726 is suitable for operating on steel or aluminium rims or new generation tyres (UHP-RFT).

IT

Nuovo smontagomme completamente automatico ideale per operare su ruote vettura e trasporto leggero fino a 26". Dotato di posizionamento pneumatico dell'utensile, Falco NA 726 è l'attrezzatura adatta ad operare su cerchi in ferro o alluminio e pneumatici di nuova generazione (UHP-RFT).

ES

Nueva desmontadora de neumáticos completamente automática, ideal para trabajar ruedas de automóviles y de transporte ligero de hasta 26". Cuenta con posicionamiento neumático. Falco NA 726 es la herramienta indicada para trabajar llantas de hierro o de aluminio y neumáticos de nueva generación (UHP-RFT).



EN

The sliding arm is connected at two points and guarantees perfect locking.

IT

Il braccio scorrevole agganciato in due punti garantisce un bloccaggio perfetto.

ES

El brazo corredizo enganchado en dos puntos garantiza un bloqueo perfecto.

EN

Tool positioning with the use of a practical pneumatic system which accelerates and simplifies operations.

IT

Posizionamento utensile tramite pratico sistema pneumatico che velocizza e semplifica le operazioni da parte dell'operatore.

ES

Colocación de la herramienta mediante un práctico sistema neumático que acelera y simplifica las operaciones de parte del operador.

EN

The tubeless tyre inflating device is integrated into the locking tracks, with direct transfer via gearbox, allowing for a stronger air flow. (Only ITR version)

IT

Dispositivo gonfia tubeless integrato nelle corsie di bloccaggio, con passaggio diretto attraverso il motoriduttore, che permette una maggiore potenza del getto d'aria. (Solo versione ITR)

ES

Dispositivo de inflado tubeless incorporado en los carriles de bloqueo, con pasaje directo a través del motorreductor, que permite una mayor potencia del chorro de aire. (Solo en la version ITR)

EN

Two speed self-centring device for greater versatility (three phase model only), single speed in NA 724 model.

IT

Autocentrante a 2 velocità per una maggiore versatilità (solo versione trifase), a 1 velocità nella versione NA 724

ES

Autocentrante de 2 velocidades para una mayor versatilidad (solo en la versión trifásica), de 1 velocidad en la versión NA 724

EN

Racing Pole:
- Allows operation on wheels of up to 13" width
- Dual height selection; minimises flexion

IT

Palo Racing:
- permette di operare su ruote fino a 13" di larghezza
- doppia altezza selezionabile per ridurre al minimo le flessioni.

ES

Columna Racing:
- permite trabajar ruedas de hasta 13" de ancho
- doble altura seleccionable reduciendo al mínimo las flexiones

**EN**

The three different adjustments of the Racing bead breaker allows operation on wheels of up to 390 mm width, optimising air and time consumption.

IT

Le tre diverse possibili registrazioni dello stallonatore racing permettono di lavorare su ruote fino a 390 mm di larghezza ottimizzando i consumi di aria e tempo.

ES

Los tres diferentes registros posibles del destalonador racing permiten trabajar ruedas de hasta 390 mm de ancho optimizando los consumos de aire y de tiempo.

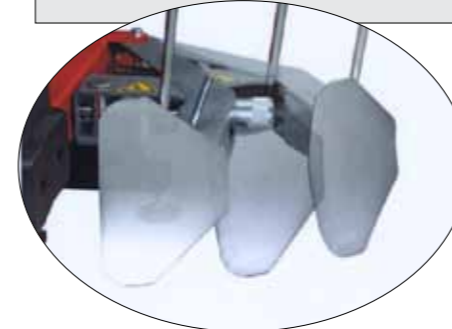
**EN**

Pole reversal by pedal-controlled pneumatic cylinder.

IT

Ribaltamento palo con cilindro pneumatico comandato a pedale

ES

Columna abatible con cilindro neumático accionado mediante pedal

Optional accessories / Optional / Extras



PN: 1 695 910 169

- Tecnoroller SL
- Tecnoroller SL
- Tecnoroller SL



PN: 1 695 102 985

- Helper
- Helper
- Helper



PN: 1 695 103 858

- Button operated tubeless tyre inflation kit
- Kit Gonfiatubeless a pulsante
- Kit de inflado tubeless de pulsador



PN: 1 695 102 725

- Turret wing protection
- Protezione ala torretta
- Protección ala torreta



PN: 1 695 101 608

- Turret tab protection kit (5 pce)
- Kit (5 pz) protezione linguetta torretta
- Kit (5 pzs) protección lengüeta torreta



PN: 1 695 103 261 - 1 695 103 216

- Low wedge and High wedge
- Zeppa bassa e zeppa alta
- Cuña baja y cuña alta



PN: 1 695 106 190

- Roller board
- Rulliera
- Transportador de rodillos



PN: 1 695 103 252

- Motorbike bead breaker support unit
- Gruppo appoggio stallonatore moto
- Grupo apoyo destalonador moto



PN: 1 695 103 545

- Scooter attachments kit (from 7")
- Kit attacchi scooter (da 7")
- Kit adaptador scooter (de 7")